

PCLD-788

16-channel Relay Multiplexer Board

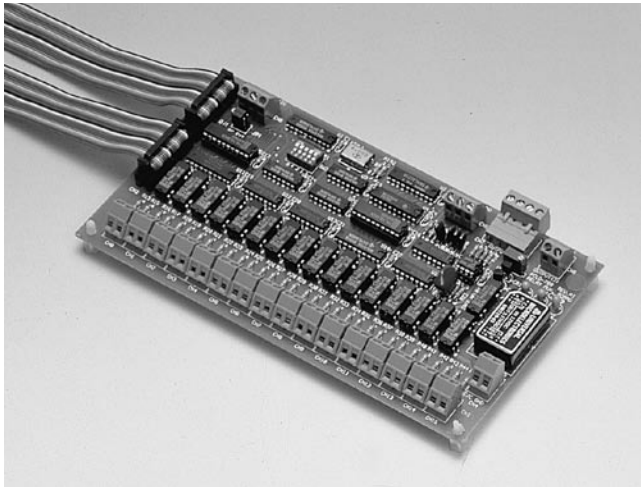

CE

Features

- 16 to 1 channel expansion
- Differential and fully isolated multiplexing
- Break-before-make relay control
- "Channel closed" signal for precise A/D triggering
- Up to 16 PCLD-788s can be cascaded for 256 channels
- Easy wiring for large channel count configuration
- On-board cold-junction circuitry for thermocouple measurement

Introduction

PCLD-788 multiplexes 16 channels into a single I/O channel of an A/D converter, voltmeter or IEEE-488-based instrument. Up to 16 PCLD-788s can be cascaded for a total of 256 fully-isolated differential channels. The PCLD-788 can be controlled by any PC-LabCard™ product via a 16-bit 20-pin digital output port, found on cards such as the PCL-711B, PCL-812PG or the PCL-818 series.

Channel selection (0-15) and board selection (0-15) are done by programming the high-order four bits and low order four bits of a digital output byte from the main I/O card in use.

Specifications

I/O

- **Channel Closed Signal** TTL-level pulse
- **Cold-junction Sensor Output** +24.4 mV/°C, 0 V at 0° C
- **Contact Rating** Break-before-make with 3 msec. minimum break time
- **Contact Resistance** 200 Ω max.
- **Input Channels** 16 isolated differential inputs
- **Programming** D/O bit 0, 1, 2 and 3 for channel selection, D/O bit 4, 5, 6 and 7 for board selection. On-board DIP switches for board-address setting
- **Max. Input Voltage** 100 V_{DC} or 100 V peak AC
- **Max. Switching Current** 0.5 A
- **Max. Switching Power** 10 W
- **Operating Time** 1 msec. max.
- **Relay Life Expectancy** 100 million cycles min. at 10 V_{DC} and 1 mA
- **Release Time** 1 msec. max.

General

- **Certifications** CE
- **Connectors**
Controller: 2 x 20-pin flat-cable connectors, second connector in parallel for daisy chaining
I/O: Screw terminals
- **Dimensions (L x W)** 205 x 114 mm (8" x 4.5")
- **Mounting** 4 x screw holes for flat surface mounting
- **Power Consumption** +5 V @ 380 mA max.

Ordering Information

- **PCLD-788** 16-channel Relay Multiplexer Board, user's manual and two 1 meter 20-pin flat cables (P/N: PCL-10120-1)

Applications

- Channel multiplexing for analog input channels of PCL-711B, PCL-812PG or PCL-818 series cards

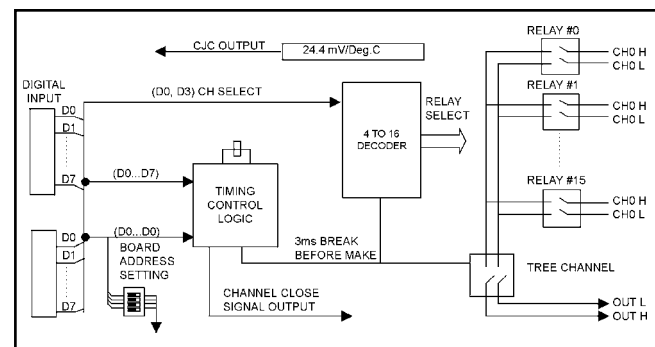

PCLD-788 Block Diagram

Pin Assignments

CN2 & CN3			
C0	1	2	C1
C2	3	4	C3
C4	5	6	C5
C6	7	8	C7
	9	10	
	11	12	
	13	14	
	15	16	
GND	17	18	GND
+5V	19	20	+12V