

Analog Output – 6 and 10 Channel

AT-AO-6, AT-AO-10

Analog Output

6 or 10 channels
12-bit resolution
300 kS/s maximum update rate
4-20 mA current sinks

Digital I/O

8 (5V/TTL) lines

NI-DAQ Software

Windows NT/98/95
(refer to page 200 for other operating systems)

Application Software

LabVIEW
BridgeVIEW
LabWindows/CVI
ComponentWorks
Measure
VirtualBench



Board	Analog Outputs	Resolution	Output Rate	Output Range	Digital I/O	Counter/Timers	Current Sinks	Triggers
AT-AO-6	6	12 bits	300 kS/s	±10 V, 0-10 V	8	–	✓	–
AT-AO-10	10	12 bits	300 kS/s	±10 V, 0-10 V	8	–	✓	–

Table 1. AO-6/10 Family Channels, Speed, and Resolution Specifications (refer to page 329 for more detailed specifications)

Overview

The National Instruments AT-AO-6 and AT-AO-10 are high-performance, 12-bit analog output boards for ISA computers. They have either 6 or 10 identical output channels, each of which has voltage output and can sink 4 to 20 mA current when connected to an external source. Because these boards are identical except for output channel count, they will be described in common and referred to as the AT-AO-6/10. The voltage output of each channel is either bipolar or unipolar and is derived from the onboard reference or an external reference. An 8-bit DIO port provides additional control capability.

Hardware

Analog Output Channels

All of the AT-AO-6/10 analog output channels are identical. Each channel can generate fast, 12-bit voltage outputs and sink currents. The voltage outputs typically settle to within 0.5 LSB of full scale (10 V) within 5 μ s.

The current outputs settle within 7 μ s and are accurate within 0.1 percent of full scale. They sink current to ground when provided with an external voltage supply in the range of 7 to 40 VDC. Each channel has two jumper-selectable options: 1) internal (10 V) or external reference voltage; 2) unipolar or bipolar output voltage swing.

Calibration

The calibration is performed under software control, thus eliminating manual trimpot adjustments. Easy recalibration ensures consistent outputs in different situations. Calibration data is stored in an onboard EEPROM.

Waveform Generation

The AT-AO-6/10 can provide 2, 4, or 6 (and 8 or 10 on the AT-AO-10) channels of simultaneous waveform generation. You can allocate the digital-to-analog (DAC) channel pairs into two channel groups, each with its own update signal, which can be one of three possible sources and one of two data transfer mechanisms. The three update signal sources include an external (EXTUPDATE*) and two internal (counter/timer 1 and counter/timer 2 outputs). The two data transfer mechanisms are DMA and interrupt. Group 0, which is serviced by DMA, can have the first 2, 4, 6, 8 or 10 channels allocated. Group 1, which is serviced by interrupts, can include any channel pairs from the remaining channels. You can thus implement flexible waveform generation with two different update rates in a very straightforward manner. A 1,024-word on-board FIFO buffer is used for seamless waveform stimulus type output applications.

Analog Output – 6 and 10 Channel

AT-AO-6, AT-AO-10

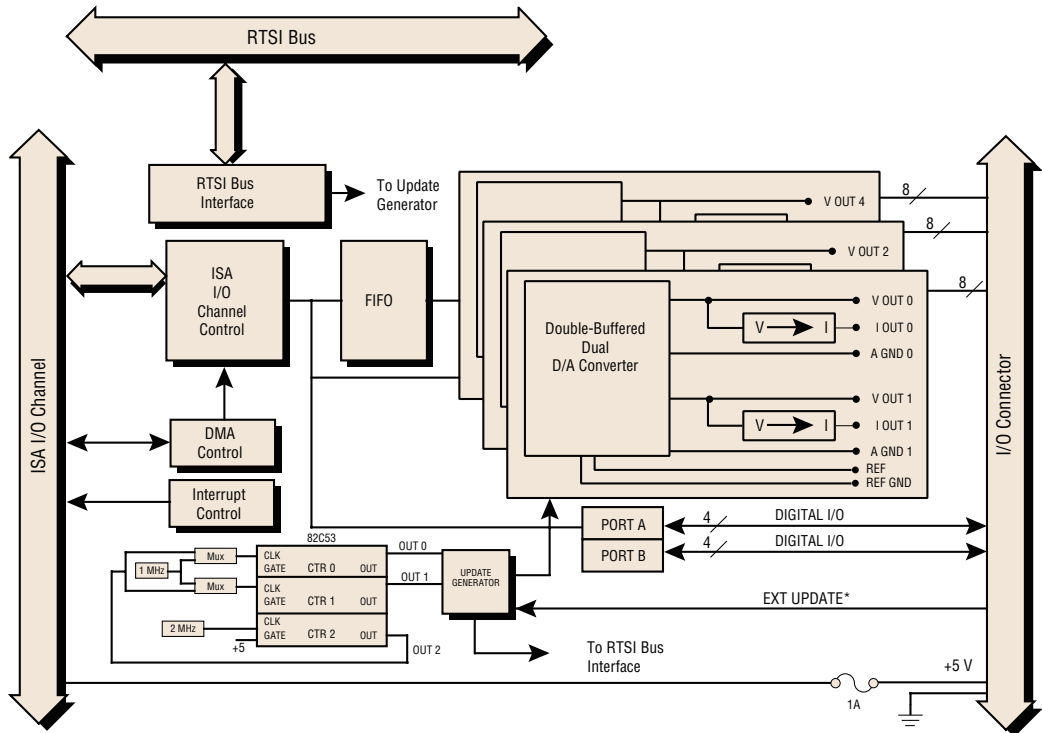

Figure 2. AO-6/10 Family Hardware Block Diagram

Analog Signal Connector

The analog outputs are available at a 50-pin ribbon cable connector. V<0..9> are the 10 voltage output channels. I<0..9>

are the 10 current output channels. AGND<0..4> are the five analog grounds, one for each channel pair. REF<0..4> are external reference input pins and GND<0..4> are their corresponding ground pins. You can clock the analog output signal externally by applying a pulse at the external update pin EXTUPDATE*. The update signal is referenced to DGND. A fused 5 VDC power signal from the AT bus is available at the I/O connector as well.

VOUT0	1	2	IOUT0
EXTREF0	3	4	RGND0
VOUT1	5	6	IOUT1
AGND0	7	8	AGND1
VOUT2	9	10	IOUT2
EXTREF2	11	12	RGND2
VOUT3	13	14	IOUT3
AGND2	15	16	AGND3
VOUT4	17	18	IOUT4
EXTREF4	19	20	RGND4
VOUT5	21	22	IOUT5
AGND4	23	24	AGND5
VOUT6	25	26	IOUT6
EXTREF6	27	28	RGND6
VOUT7	29	30	IOUT7
AGND6	31	32	AGND7
VOUT8	33	34	IOUT8
EXTREF8	35	36	RGND8
VOUT9	37	38	IOUT9 (2.5 V)
AGND8	39	40	DIO0
DIO1	41	42	DIO2
DIO3	43	44	DIO4
DIO5	45	46	DIO6
DIO7	47	48	EXTUPDATE*
DGND	49	50	+5 V

Figure 1. AO-6/10 Family I/O Connector



For detailed specifications, refer to page 329

Ordering Information

AT-AO-6776541-01
AT-AO-10776542-01

Includes NI-DAQ for Windows NT/98/95 on CD. See page 228 for more details

Example Configurations

DAQ Board	Cable (page 305-309)	Accessory (page 295-304)
AT-AO-6	NB1 (180524-10)	CB-50 (776164-90)
AT-AO-10	NB1 (180524-10)	CB-50 (776164-90)

Refer to page 205 for more detailed cable and accessory options.

Data Acquisition

Specifications

AT-AO-6/10

These specifications are typical at 25 °C unless otherwise stated.

Analog Output

Output Characteristics

Number of channels

AT-AO-10	10 voltage or current outputs
AT-AO-6	6 voltage or current outputs

Resolution	12 bits, 1 in 4096
Maximum update rate	300 KS/s, system dependent
Type of DAC	Double buffered, multiplying
FIFO buffer size	1,024 samples
Data transfers	DMA, interrupts, programmed I/O
DMA modes	single transfer, demand transfer

Transfer Characteristics

Relative accuracy (INL)	±0.5 LSB max
DNL	±1.0 LSB max
Monotonicity	12 bits, guaranteed after calibration
Offset error	
After calibration	±1 mV max
Before calibration	±200 mV max
Gain error (relative to internal reference)	
After calibration	±0.01% of reading max
Before calibration	±0.5% of reading max
Gain error (relative to external reference)	±0.1% of reading max, not adjustable

Voltage Output

Ranges	±10 V, ±EXTREF, 0 to 10 V, 0 to EXTREF; jumper selectable
Output coupling	DC
Output impedance	0.1 Ω max
Current drive	±5 mA max
Load impedance	500 pF max
Protection	Short-circuit to ground
Power-on state	0 V bipolar, 5 V unipolar
External reference input	
Range	±10 V
Overvoltage protection	±25 powered on or off
Input impedance	10 kΩ
Bandwidth (-3 dB)	1 MHz

Current Output

Range	4 to 20 mA
Type	Sink to ground, requires external excitation source
Output impedance	1 GΩ min
Excitation voltage range	+7 to +40 V
Absolute accuracy	±0.1% FSR
Protection	Short circuit to ground and open circuit
Power-on state	4 mA bipolar, 12 mA unipolar

Dynamic Characteristics

Settling time (full scale step)	10 μs to ±0.5 LSB accuracy
Slew rate	10 V/μs, 7.5 mA/μs

Stability

Offset temperature coefficient	±50 μV/°C
Gain temperature coefficient	
Internal reference	±10 ppm/°C
External reference	±5 ppm/°C

Digital I/O

Number of channels	8 input/output
Compatibility	5V/TTL
Power-on state	Input (High impedance)
Data transfers	Programmed I/O
Digital logic levels	

Level	Minimum	Maximum
Input low voltage	0 V	0.8 V
Input high voltage	2.2 V	5.25 V
Output low voltage ($I_{out} = 24$ mA)	–	0.5 V
Output high voltage ($I_{out} = 2.6$ mA)	2.4 V	–

RTSI

Trigger lines	7
---------------	---

Bus Interface

AT	Slave
----	-------

Power Requirements

AT-AO-6	
+5 VDC (±5%)	0.6 A
+12 VDC (±5%)	60 mA + load
-12 VDC (±5%)	60 mA + load
AT-AO-10	
+5 VDC (±5%)	1.6 A
Power available at I/O connector	+4.65 to +5.25 VDC, 1 A

Physical

Dimensions (not including connectors)	34.0 by 11.4 cm (13.3 by 4.5 in.)
I/O connector	50-pin male

Environment

Operating temperature	0 to 55 °C
Storage temperature	-20 to 70 °C
Relative humidity	10 to 90%, noncondensing