

Low-Cost Multifunction I/O – 100 kS/s, 12-Bit, 8 Analog Inputs

1200 Family

1200 Family

PCI-1200
DAQCard-1200
Lab-PC-1200
Lab-PC-1200AI
DAQPad-1200

Analog Inputs

8 single-ended, 4 differential channels
100 kS/s sampling rate
12-bit resolution

Analog Output (not for Lab-PC-1200AI)

2 channels, 12-bit resolution

Digital I/O

24 (5 V/TTL) lines in 8-bit ports

Counter/Timers

Three, 16-bit resolution

Triggering

Digital

Driver Software

NI-DAQ
Windows 2000/NT/9x
Mac OS*
*not for all hardware,
refer to page 192

Application Software

LabVIEW
LabWindows/CVI
ComponentWorks
VirtualBench
Measure
BridgeVIEW
Lookout

Calibration Certificate Included!

(refer to page 216)



Make sure you consider our new low-cost 12-bit E Series products – refer to page 239.

Bus	Analog Inputs	Resolution	Sampling Rate	Input Range	Analog Outputs	Resolution	Output Rate	Output Range	Digital I/O	Counter/Timers	Triggers
PCI, PCMCIA, ISA, Parallel Port	8 SE/4 DI	12 bits	100 kS/s	up to ±5 V	2 ¹	12 bits ¹	1 kS/s ¹	±5 V	24	3, 16-bit	Digital

¹No analog outputs on Lab-PC-1200AI

Table 1. 1200 Family Channel, Speed, and Resolution Specifications (refer to page 314 for more detailed specifications)

Overview

The 1200 Family devices are low-cost, multifunction I/O devices with up to 100 kS/s, 12-bit performance on 8 single-ended or 4 differential analog inputs. The 1200 Family features digital triggering capability; three 16-bit, 8 MHz counter/timers; two 12-bit analog outputs; and 24 digital I/O lines. The 1200AI does not include the two analog outputs.

Hardware Analog Input

The 1200 Family has eight single-ended or 4 differential 12-bit analog input channels. The voltage input range is software programmable for 0-10 V (unipolar) or ±5 V (bipolar). A software-programmable gain amplifier has gain selections of 1, 2, 5, 10, 20, 50, or 100.

The single-channel sampling rate of the ADC is 100 kS/s. The PCI, DAQCard, and Lab-PC versions can sustain this rate, but the DAQPad cannot. The sustainable data transfer rate to a standard PC parallel port is 25 kS/s (depending on your computer). If you need an external solution with faster sampling, consider the DAQPad-6020E for USB, (100 kS/s, page 241) and the DAQPad-6070E for IEEE 1394 (1.25 MS/s, page 226). When scanning multiple channels, the maximum sampling rate for all 1200 family products is 83.3 kS/s at a gain of 1.

Data acquisition with the 1200 Family devices is available in three modes: 1) continuous acquisition of a single channel, 2) multichannel acquisition with continuous scanning, or 3) multichannel acquisition with interval scanning with a resolution of 1 μs.

The 1200 Family devices have two hardware triggering modes – pretrigger mode and posttrigger mode. In pretrigger mode, the device collects samples until a trigger is received at the external trigger input, and then continues to collect a specified number of samples. In posttrigger mode, the device collects a specified number of samples after it receives a trigger.

Analog Output

The 1200 Family has two double-buffered 12-bit DACs that are connected to two analog output channels. You can independently configure each channel through software for unipolar (0-10 V) or bipolar (±5 V) operation. The resolution of the 12-bit DAC is 2.44 mV in both polarities.

ACH0	1	2	ACH1
ACH2	3	4	ACH3
ACH4	5	6	ACH5
ACH6	7	8	ACH7
AISENSE/AINGD	9	10	DAC0OUT ¹
AGND	11	12	DAC1OUT ¹
DGND	13	14	PA0
PA1	15	16	PA2
PA3	17	18	PA4
PA5	19	20	PA6
PA7	21	22	PB0
PB1	23	24	PB2
PB3	25	26	PB4
PB5	27	28	PB6
PB7	29	30	PC0
PC1	31	32	PC2
PC3	33	34	PC4
PC5	35	36	PC6
PC7	37	38	EXTTRIG
EXTUPDATE	39	40	EXTCONV ⁺
OUTB0	41	42	GATB0
OUTB1	43	44	GATB1
CLKB1	45	46	OUTB2
GATB2	47	48	CLKB2
+5V	49	50	DGND

¹Not available on Lab-PC-1200AI

Figure 1. 1200 Family I/O Connector

Data Acquisition

Low-Cost Multifunction I/O – 100 kS/s, 12-Bit, 8 Analog Inputs

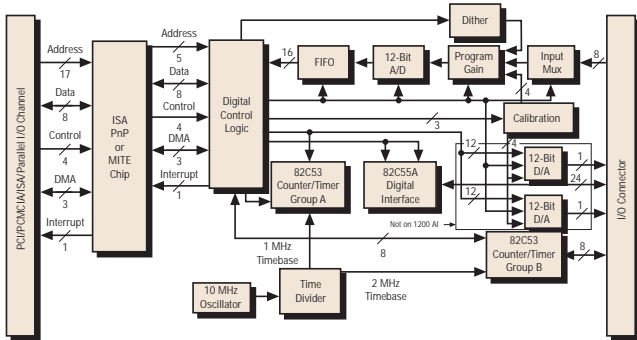

Figure 2. 1200 Family Hardware Block Diagram

DAQPad-1200 Power

The DAQPad-1200 is powered by any 9 to 42 VDC source. With the AC adapter unit included, you can power the DAQPad-1200 from any standard 120 VAC or 230 VAC source.

The optional BP-1 rechargeable battery pack is the same size as the DAQPad-1200 and powers it for 11 hours. The charger unit included with the BP-1 is not CE certified.

BNC and Breadboard Accessories

The BNC-2081 accessory has labeled BNC connections for the analog signals of the 1200 Family. The SC-2071 and SC-2072 are breadboard accessories with labeled and numbered screw terminals, respectively; the 1200 device must be in single-ended mode to use the SC-2071.

Self-Calibration

The analog inputs and outputs of the 1200 Family have self-calibration circuitry to correct for gain and offset errors. You can use the permanently-stored factory calibration constants or store additional sets of constants for different operating conditions in the user-modifiable section of an EEPROM on the device.



Make sure you consider our new low-cost E Series products – refer to page 239.

Digital I/O

The 1200 Family devices have 24 digital I/O lines that are 5 V/TTL compatible and configurable as three 8-bit ports for input, output, bidirectional, or handshaking modes. The digital output ports of the 1200 series can sink 2.5 mA on each line.

Counter/Timer

The 1200 Family uses two 82C53 counter/timer integrated circuits, each containing three independent 16-bit counter/timers. One 82C53 is dedicated for A/D and D/A timing. The three counters on the other 82C53 are available for general time-related functions, such as clock output, pulse output, and event counting. Of these three counters, one may be required for timing of analog I/O, and one has a built-in 20 MHz source clock.

I/O Connector

The I/O connector is a 50-pin male ribbon cable connector diagrammed in Figure 1. ACH<0..7> are eight analog input channels. DAC0OUT and DAC1OUT are the two analog output channels. EXUPDATE, EXTCONV, and EXTTRIG are TTL lines through which you can externally control analog I/O. CLKB<1..2>, GATB<0..2>, and OUTB<0..2> are the clock, gate, and output of the user-available counters. PA<0..7>, PB<0..7>, and PC<0..7> are the three 8-bit digital I/O ports.

DAQPad-1200 Parallel Port Interface

The DAQPad-1200 includes a 1 m parallel port cable with two 25-pin D-Sub connectors. The DAQPad-1200 rear panel includes two parallel port connectors, Port A for connection to the PC parallel port, and Port B, for transparent pass-through connection to any other standard parallel port device.

Ordering Information

1200 Family

PCI-1200 and NI-DAQ for

Windows 2000/NT/9x.....777386-01
Mac OS777097-01

DAQCard-1200 and NI-DAQ for

Windows 2000/NT/9x.....777087-01
Mac OS777087-02

Lab-PC-1200777227-01

Lab-PC-1200AI777292-01

DAQPad-1200 for Parallel Port with AC adapter

U.S. 120 VAC.....776895-01
Universal Euro 240 VAC.....776895-31
United Kingdom 240 VAC776895-06

Includes NI-DAQ for Windows 2000/NT/9x on CD unless otherwise noted. See pages 192 and 210 for more details.

BP-1 rechargeable battery pack with charger

120 VAC776896-01
240 VAC776896-31

BNC-2081776599-90

SC-2071776358-91

SC-2072776358-92

Example Configurations

Family	DAQ Board	Cable (page 297)	Accessory (page 292)
1200	PCI-1200	NB1 (180524-10)	CB-50LP (777101-01)
	DAQCard-1200	PR50-50F (182799-01)	CB-50LP (777101-01)
	Lab-PC-1200	NB1 (180524-10)	CB-50LP (777101-01)
	Lab-PC-1200AI	NB1 (180524-10)	CB-50LP (777101-01)
1200AI	DAQPad-1200	NB1 (180524-10)	CB-50LP (777101-01)

For more detailed cable and accessory options, refer to pages 286-299.

Specifications

1200 Family

These specifications are typical at 25 °C unless otherwise stated.

Analog Input Input Characteristics

Number of channels.....	8 single-ended, or 4 differential, software selectable
Type of ADC.....	Successive approximation
Resolution.....	12 bits, 1 in 4,096
Maximum sampling rate	
PCI, DAQCard, Lab-PC.....	100 kS/s
DAQPad.....	100 kS/s to FIFO; 25 kS/s to PC with standard Centronics port

Input signal ranges

Gain (Software Selectable)	Range (Software Selectable)	
	Bipolar	Unipolar
1	±5 V	0 to 10 V
2	±2.5 V	0 to 5 V
5	±1 V	0 to 2 V
10	±500 mV	0 to 1 V
20	±250 mV	0 to 500 mV
50	±100 mV	0 to 200 mV
100	±50 mV	0 to 100 mV

Input coupling.....	DC
Maximum working voltage (signal + common mode).....	In differential or NRSE mode, the negative input/AISENSE should remain within ±5 V (bipolar) or -5 to 2 V (unipolar) of AGND except for the DAQCard-1200, where the values are ±6 V (bipolar) and -6 to 2 V (unipolar). The positive input should remain within -5 V to +10 V of AGND. For the DAQCard-1200 in RSE mode, the input signal referenced to AGND should remain within ±5 V (bipolar) or 0 to 10 V (unipolar).

Overvoltage protection	
PCI, DAQCard, Lab-PC.....	±35 V powered on, ±25 V powered off
DAQPad.....	±42 V powered on, ±15 V powered off
Inputs protected.....	ACH<0..7>

FIFO buffer size	
PCI.....	4,096 samples
DAQCard.....	1,024 samples
Lab-PC.....	512 samples
DAQPad.....	2,048 samples

Data transfers	
PCI, Lab-PC.....	DMA, interrupts, programmed I/O
DAQCard, DAQPad.....	Interrupts, programmed I/O

DMA modes	
PCI.....	Scatter-gather
Lab-PC.....	Single transfer
Dither.....	Available

Transfer Characteristics

Relative accuracy.....	±0.5 LSB typical dithered, ±1.5 LSB max undithered
DNL.....	±1 LSB max
No missing codes.....	12 bits, guaranteed
Offset error	

Error		PCI, DAQCard, Lab-PC	DAQPad
Pregain	After calibration	±10 µV max	±5 µV max
	Before calibration	±20 mV max	±15 mV max
Postgain	After calibration	±1 mV max	±360 µV max
	Before calibration	±200 mV max	±150 mV max

Gain error (relative to calibration reference)	
After calibration.....	0.02% of reading max
Before calibration.....	±2% of reading max

Amplifier Characteristics

Input bias current	
PCI, DAQCard, Lab-PC.....	±100 pA
DAQPad.....	±200 pA
Input offset current.....	±100 pA

Input impedance	
Normal powered on.....	100 GΩ in parallel with 50 pF
Powered off.....	4.7 kΩ min
Overload.....	4.7 kΩ min
CMRR.....	70 dB typical, DC to 60 Hz

Dynamic Characteristics

Bandwidth (small signal -3 dB)

Gain	PCI, DAQCard, Lab-PC	DAQPad
1 to 10	250 kHz	400 kHz
20	150 kHz	200 kHz
50	60 kHz	80 kHz
100	30 kHz	40 kHz

Settling time for full-scale step

Gain	Accuracy ±0.024% (±1 LCB)		
	PCI, Lab-PC µs typical/µs max	DAQCard µs typical/µs max	DAQPad µs max
1	10/14	-/10	25
2 to 10	13/16	-/10	25
20	15/19	12/15	25
50	27/34	25/30	25
100	60/80	60/80	60

System noise (including quantization error) in LSB_{rms}

Gain	PCI, DAQCard, Lab-PC		DAQPad	
	Dither Off	Dither On	Dither Off	Dither On
1 to 50	0.3	0.5	0.3	0.6
100	0.5	0.7	0.6	0.8

Stability

Recommended warm-up time.....	15 minutes
Offset temperature coefficient	
Pregain.....	±15 µV/°C
Postgain.....	±100 µV/°C
Gain temperature coefficient	
PCI, DAQCard, Lab-PC.....	±40 ppm/°C
DAQPad.....	±50 ppm/°C

Analog Output (not for Lab-PC-1200A)

Output Characteristics

Number of channels.....	Two voltage
Resolution.....	12 bits, 1 in 4,096
Typical update rate.....	1 kS/s (system dependent)
Type of DAC.....	Double buffered, multiplying
Data transfers.....	Interrupts, programmed I/O

Transfer Characteristics

Relative accuracy.....	±0.25 LSB typical, ±0.50 LSB max ±0.50 LSB typical, ±1.0 LSB max (DAQCard)
DNL.....	±0.25 LSB typical, ±0.75 LSB max ±0.50 LSB typical, ±0.90 LSB max (DAQCard)
Monotonicity.....	12 bits, guaranteed
Offset error	
After calibration.....	±0.2 mV max; ±0.5 mV max for DAQCard
Before calibration.....	±50 mV max; ±75 mV max for DAQCard
Gain error (relative to internal reference)	
After calibration.....	0.01% of reading max 0.02% of reading max (DAQCard)
Before calibration.....	±1% of reading max ±2% of reading max (DAQCard)

Voltage Output

Ranges.....	0 to 10 V, ±5 V, software selectable
Output coupling.....	DC
Output impedance.....	0.2 Ω typical 0.5 Ω typical (DAQCard)
Current drive.....	±2 mA 1 mA max per channel (DAQCard)
Protection.....	Short circuit to ground 80 mA momentary short-circuit protection to ground (DAQCard)

1200 Family (continued)

Power-on state
 PCI, DAQCard, Lab-PC 0 V
 DAQPad 0 V bipolar mode, 5 V unipolar mode

Dynamic Characteristics

Settling time to full-scale range (FSR)
 PCI, Lab-PC 5 μ s to ± 1 LSB
 DAQCard 20 μ s to ± 1 LSB
 DAQPad 6 μ s to ± 1 LSB

Stability

Offset temperature coefficient
 PCI, DAQCard, Lab-PC ± 50 μ V/ $^{\circ}$ C
 DAQPad ± 60 μ V/ $^{\circ}$ C
 Gain temperature coefficient
 PCI, DAQCard, Lab-PC ± 30 ppm/ $^{\circ}$ C
 DAQPad ± 10 ppm/ $^{\circ}$ C

Digital I/O

Number of channels 24 I/O (three 8-bit ports; uses the 82C55A PPI)

Compatibility 5 V/TTL

Digital logic levels

Level	Minimum	Maximum
Input low voltage	-0.3 V	0.8 V
Input high voltage	2.2 V	5.3 V
Output low voltage ($I_{out} = 2.5$ mA)	-	0.4 V
Output high voltage ($I_{out} = 2.5$ mA)	3.7 V	-

Handshaking 2-wire, 2 ports
 Power-on state Input
 Protection -0.5 to 5.5 V powered on, ± 0.5 V powered off
 Data transfers Interrupts, programmed I/O

Timing I/O

Number of channels 3 counter/timers (uses two 82C53 STCs)
 Protection -0.5 V to 5.5 V powered on, ± 0.5 V powered off
 Resolution 16 bits
 Compatibility 5 V/TTL, counter gate and clock inputs are pulled up with 100 k Ω onboard resistors
 Base clock available 2 MHz
 Base clock accuracy ± 50 ppm max, $\pm 0.01\%$
 Maximum source frequency 8 MHz
 Minimum source pulse duration 60 ns
 Minimum gate pulse duration 50 ns

Digital logic levels

Level	Minimum	Maximum
Input low voltage	-0.3 V	0.8 V
Input high voltage	2.2 V	5.3 V
Output low voltage ($I_{out} = 2.1$ mA for PCI, Lab-PC) ($I_{out} = 4$ mA for DAQCard, DAQPad)	-	0.45 V
Output high voltage ($I_{out} = 0.92$ mA for PCI, Lab-PC) ($I_{out} = 1$ mA for DAQCard, DAQPad)	3.7 V	-

Data transfer Interrupts, programmed I/O

Digital Trigger

Compatibility 5 V/TTL
 Response Rising edge
 Pulse width 50 ns min

Bus Interface

PCI Master, slave
 DAQCard, Lab-PC, DAQPad Slave

Power Requirements

+5 VDC ($\pm 5\%$)
 PCI 425 mA
 DAQCard 150 mA, 50 mA power-down mode
 Lab-PC 185 mA
 Lab-PC-1200AI 150 mA
 +12 VDC
 DAQPad 250 mA
 Power available at I/O connector +4.65 to +5.25 V, 400 mA fused
 +5 VDC, 500 mA (DAQCard)

Physical

Dimensions
 PCI, Lab-PC 17.5 x 10.6 cm (6.9 by 4.2 in.)
 DAQCard Type II PC Card
 DAQPad 14.6 by 21.3 by 3.8 cm
 (5.8 by 8.4 by 1.5 in.)
 Weight
 DAQPad 0.77 kg (1.7 lb)
 I/O connectors 50-pin male
 Paralle port connector
 Type 2 female 25-pin D-Sub, EPP and SPP (Centronics)
 Throughput 180 kbytes/s (EPP), 41 kbytes/s (Centronics)

Environment

Operating temperature 0 to 50 $^{\circ}$ C, DAQCard should not exceed 50 $^{\circ}$ C while in PCMCIA slot
 Storage temperature -20 to 70 $^{\circ}$ C
 Relative humidity 5% to 90% noncondensing

BP-1 Rechargeable Battery Pack

Output 12 VDC, 3.2 Ah
 Run time with DAQPad 5 h loaded at 350 mA from +5 V I/O;
 11 h unloaded
 Dimensions 14.6 by 21.3 by 3.8 cm
 (5.8 by 8.4 by 1.5 in.)
 Weight 1.92 kg (4.2 lb)

Certifications and Compliances¹

CE Mark Compliance **CE**

¹The charger included with the BP-1 is not CE compliant.